

# Kebni Gimbal Ka130MIL

130 cm Ka-band | Military Maritime Stabilized VSAT System

## Designed for Navy Vessels

The Kebni Gimbal Ka130MIL is a high performance stabilized VSAT antenna proven according to US Military standards for vessels participating in sea warfare and defence. The antenna is easy to install, light and small - yet reliable and providing superior radio performance to support mission critical applications used on a modern battle ship.

## Gimbal design

The Kebni Gimbal is a stabilized VSAT antenna built on a unique and proven gimbals technology. The design enables shorter geometric path and less rotation torque for each axis, extending the life of the mechanical parts of the antenna as the system is exposed to less stress than a centre-pole system. The cross-level axis also solves problems related to the zenith paradox occurring in a wide belt around the equator at high reflector elevations.

## Superior Reflector Solution

The antenna design is of Prime Focus type and the reflector is made of carbon fibre, standard for KebNi Maritime antennas. The RF equipment is therefore light and easy to manoeuvre for the stabilizing platform, which facilitates fast and precise movements. The antenna complies with the requirements of Eutelsat and provides several technical advantages, such as;

- High gain
- Low side lobes
- High cross-pol discrimination
- Up to 50W BUC
- EIRP (with 20W BUC) 63 dBW
- Resistant to disturbance from other radio sources

## Fast and Robust System

The antenna system is fast due to the gimbal design with AC servo motors on each axis and the gradient satellite tracking method on all 3 axes. The antenna locks on the satellite within 8 seconds, starting from its parking position. Robustness is built into the system, partly because of the solid rig construction, but also because the gimbal design enables less weight to move and a minimum of movement for each axis – all of the time.

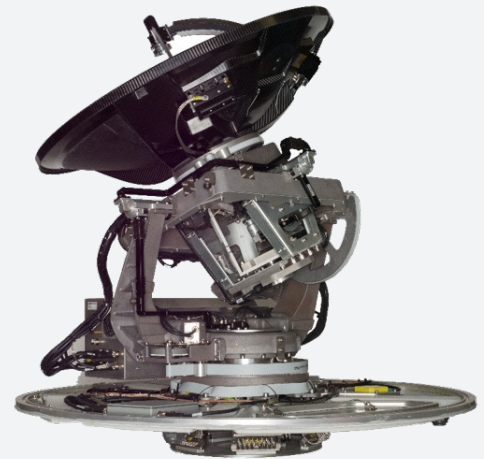

## KEY FEATURES

- ✓ 3 axes - No zenith problems at equator
- ✓ Real Military standard
- ✓ Fast acquisition
- ✓ High MTBF
- ✓ Modem agnostic
- ✓ SNMP O&M

## Remote Operation and Performance

The Kebni Gimbal antennas are generally designed for remote Operation and Maintenance. The functionality includes:

- Real time supervision with access to performance statistics
- Remote management using SNMP
- Remote access control using SSH

## Compliance to Standards

Kebni Gimbal Ka130MIL is tested and approved based on military standard specifications concerning vibration, shock, and EMC according to MIL STD 810G and MIL STD 461F.

# Kebni Gimbal Ka130MIL

## Technical specifications

Weight	~ 240 Kg
Height	1.70 m
Diameter	1.75 m
Stabilisation Type	3-axes gimbals. AC servo low inertia belt drive.
Antenna Type	Prime Focus
Reflector Diameter	1.3 m (51")
Radome Size	H: 1.70 m (67") D: 1.75 m (69")
Weight including Radome	240 kg (530 lbs)
Frequency	Rx: 20.2 – 21.2 GHz Tx: 30.0 – 31.0 GHz
Antenna Gain	Rx: 47.5 dBi / Tx: 50.5 dBi
Reflector Material	Carbon Fibre
Axial Ratio	1.0
Signal Polarization	Circular RHCP or LHCP
G/T (@ 20° elevation, typical)	24 dB/K @ 20.7 GHz
Maximum BUC Power	50W internal BUC
Antenna Movement, azimuth	Continuous, unlimited, (slip ring)
Antenna Movement, Elevation	-5° – 120°
Antenna Movement, Cross Level	± 30°
Antenna Movement, Polarisation	± 120°
Ship Motion	± 30° per 4s in pitch, roll and yaw
Heave	+/- 5m @3s
Pointing accuracy	0.1° RMS
GPS Antenna	Built in
Radar Rejection	>80 dB @ 9.6 GHz
Radome Material	Polyester laminate with Trident foam core
Compass Interface	NMEA 0183
Nominal Voltage:	115VAC @ 60 Hz or 220 – 230VAC @ 50/60 Hz
Operating Temperature	-20 – 60 °C, with Air Conditioner MIL-STD-810G Method 501.5 & 502.5
Humidity	97% @ 30 °C MIL-STD-810G Method 507.5 procedure II
Vibration Operating	MIL-STD-810G, Method 528, Table 528.III
Shock Operating	20 g, half-sine 11 ms, MIL-STD-810G, Method 516.6
Shock Non-Operating	Transverse/Longitudinal: 20 g 20 ms; 40 g 6 ms, Vertical: 15 g 20 ms; 30 g 6 ms MIL-STD-810G Method 516.6
EMC	MIL STD 461F complete including RS103 200V/m, (2 MHz – 40 GHz)

Note: Specifications subject to change without further notice

### Supports fast deployment

Antenna completely **assembled**, **balanced** and **tested** at factory.

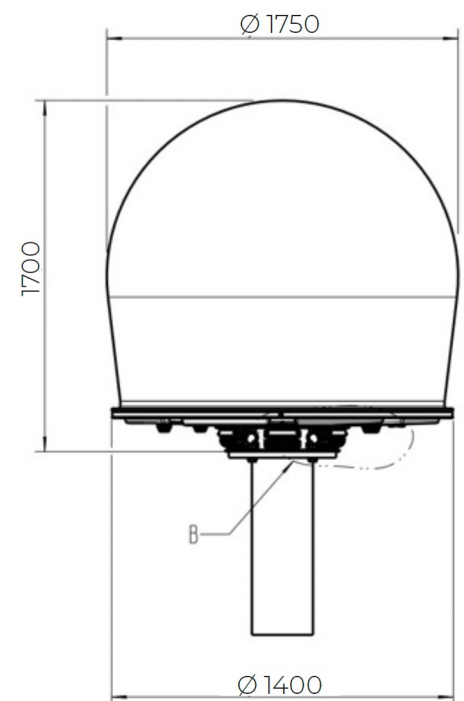

Radome size in mm.